

Utilisation - Use

Masses destinées à la vérification ou l'étalonnage des masses de classe M et avec des instruments de pesage de classe III (précision moyenne).

Weights intended for use in the verification or calibration of class M weights, and for use with weighing instruments of medium accuracy class III.

Description - Description

Référentiel - Conformité : Recommandation OIML R111

Conformity : OIML R111 Recommendation



Matière : Fonte grise

Material : Cast iron (grey)

Masse volumique : 7100 ±200 kg/m³

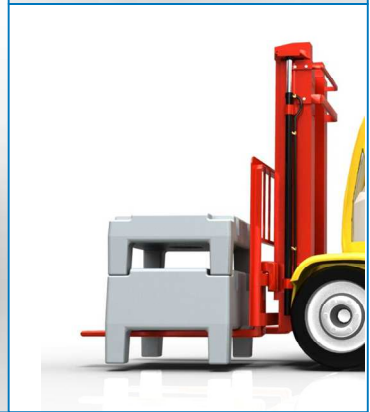
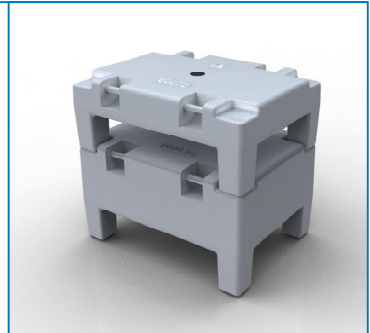
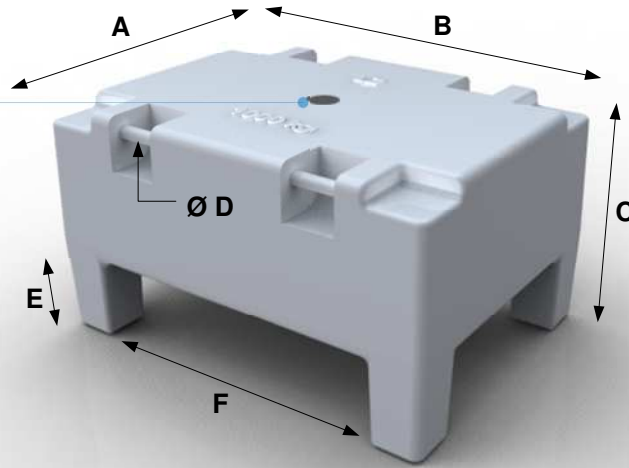
Density



Identification <i>Identification</i>	En option <i>Option</i>
	 <p>ACCREDITATION N° 2.1218 MASSE</p> <p>Portée disponible sur www.cofrac.fr</p> <p>Etalonnage <i>Calibration</i></p>

Caractéristiques techniques - Technical specifications

Corps coulé en fonderie

Block casting coming from foundry

Finition : Peinture

Finish : Painting

Cavité d'ajustage scellée par une pastille de plomb

Adjusting cavity sealed with a lead plug

Magnétisation permanente < 250 µT

Permanent magnetisation

Valeur nominale Nominal value	100 kg	200 kg	500 kg	1000 kg	2000 kg
Réf. - Ref.	264 23 16	265 23 16	269 23 16	361 23 16	362 23 16
A	600	600	600	600	600
B	800	800	800	800	800
C	204	222	310	460	760
Ø D	25	25	25	25	25
E	160	160	160	160	160
F	600	600	600	600	600
EMT ± δm en g MPE ± δm in g	5	10	25	50	100

EMT : Erreurs Maximales Tolérées - PE : Maximum Permissible Errors

Dimensions en mm - Dimensions in mm

Nos accessoires - Accessories

650 0000 – 100 kg
651 0000 – 200 kg
652 0000 – 500 kg



Coffret bois - Wooden box

667 0000



Système de préhension
Handling system

663 0000



Gants cuir - Leather gloves